



5300 Beethoven Street, Los Angeles, CA 90066
 TEL: (310)306-5556 • FAX: (310)577-9887
 WEB: www.ophirrf.com • E-MAIL: sales@ophirrf.com

MODEL 7034
10 KHz to 400 MHz
TWO CHANNEL
BROADBAND,
POWER RF AMPLIFIER

**Solid State
 Broadband High Power
 RF Amplifier**

The 7034 is a two channel broadband system that covers the 10 KHz—400 MHz frequency range with a single RF input and Single RF output port.

This integrated system provides 400 Watts of power as detailed in the specification for any selected frequency range.

The system includes high power RF switches controlled by the system controller. The IEEE-488/RS232/Ethernet and/or Front panel key-pad provides full control and reduces the power consumption to the minimum by shutting down the un-selected channel.

The System is configured in a Rear panel Connectors configuration.

Like all OPHIR_{RF} amplifiers, the 7034 comes with an extended multiyear warranty backed by Ophir RF's commitment to total customer satisfaction.

	Parameter	Specification @ 25° C
Electrical		
1	Frequency Range Channel 1: Channel 2:	0.01 - 10 MHz 10 - 400 MHz
2	Power Output PSAT Channel 1: Channel 2:	400 Watts Minimum 400 Watts Minimum
3	Power Output P1dB Channel 1: Channel 2:	250Watts Minimum 250 Watts Minimum
4	Small Signal Gain Channel 1: Channel 2:	56 dB Minimum 56 dB Minimum
5	Small Signal Gain Flatness	± 2.0 dB max
6	Input VSWR	2:1 max
7	Harmonics Channel 1: Channel 2:	-15dBc @ 250 Watts -20 dBc @ 250 Watts
8	Spurious Signals	-60 dBc typical @ P1dB
9	Input/Output Impedance	50 Ohms nominal
10	AC Input Power Channel 1 Channel 2	One Channel Tx at a time 3,000 Watts Maximum 3,000 Watts Maximum
11	AC Input	100 – 240 VAC, single phase
12	RF Input drive required for Psat	0 dBm Nominal
13	Max. RF drive without damage	+ 3 dBm
Mechanical		
14	Dimensions	19" x 8.75" x 26"
15	Weight	95 lbs.
16	Connectors	Type-N
17	Grounding	Chassis
18	Cooling	Internal Forced Air
Environmental		
19	Operating Temperature	0° C to +50° C
20	Operating Humidity	95% Non-condensing
21	Operating Altitude	Up to 10,000' Above Sea Level
22	Shock and Vibration	Normal Truck Transport

Specifications subject to change without notice



FE MODEL SHOWN



5300 Beethoven Street, Los Angeles, CA 90066
 TEL: (310)306-5556 • FAX: (310)577-9887
 WEB: www.ophirrf.com • E-MAIL: sales@ophirrf.com

MODEL 7034
10 KHz to 400 MHz
TWO CHANNEL
BROADBAND,
POWER RF AMPLIFIER

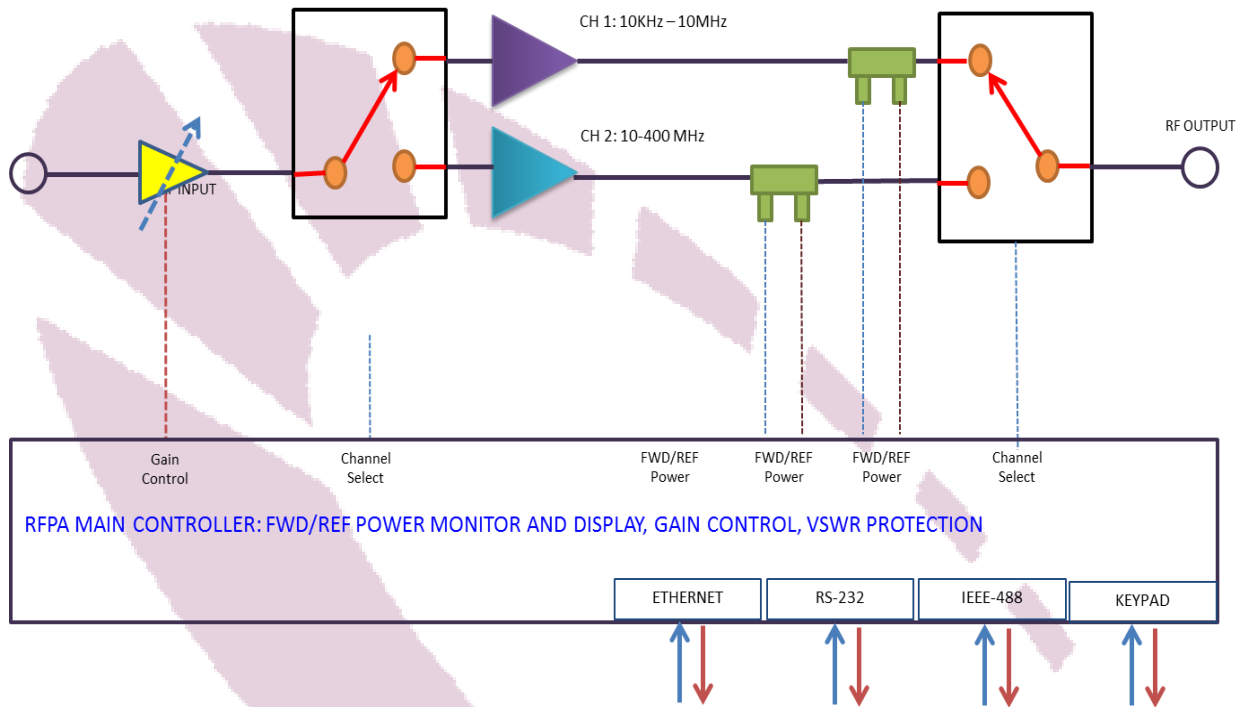

CIRCUIT INDICATIONS

- ◇ Forward Power
- ◇ Reflected power
- ◇ VSWR Fault
- ◇ Temp Fault
- ◇ Gain Setting (VVA) percentage

CIRCUIT PROTECTIONS

- ◇ Thermal Overload
- ◇ Over Current
- ◇ Over Voltage
- ◇ Open or Short VSWR Conditions

RFPA SYSTEM OPTIONS

- ◇ Switched Filter Bank
- ◇ Input Power Requirements
- ◇ Ruggedized Version
- ◇ Cabinet Requirements
- ◇ Outdoor Version
- ◇ Sample Ports
- ◇ Racking Options
- ◇ Many More!
- ◇ **Consult Factory with Specific Requirements**

CIRCUIT CONTROL

- ◇ Standby (amplifier disable)
- ◇ Gain/power setting with 20 dB range
- ◇ VSWR protection Reset
- ◇ Channel Select

